

586/6

M6  
M8  
M10

M8  
M10  
M12

EN

Threaded rod cutter



Unior d.d.  
Kovaška cesta 10  
3214 Zreče, Slovenia  
T: +386 3 757 81 00  
www.uniortools.com

90605721

 **UNIOR**<sup>®</sup>  
uniortools.com

## CUTTING THREAD RODS M6, M8, M10 (M8, M10, M12)

1. Fully open right handle rod (pos. 1) to max. position.
2. Insert thread rod into correct cutting dies diameter.
3. Thread rod should be correctly aligned into screw pitches.
4. The threaded rod is cut by closing the right handle towards the left one. If the threaded rod cutter is used on the floor then you should stand on support plate (pos. 2).
5. In case that burrs stay on the rod tube we can use thread corrector and removed burrs (pos. 8).

## CHANGE THE CUTTING DIES M6, M8, M10 (M8, M10, M12) (art. 586.1/7)

1. First undo nut M14 (pos. 3) with a 2.5mm hex key.
2. Undo the main centric bolt M14 (pos. 4).
3. Disassemble both jaws (pos. 5).
4. Used cutting dies (pos. 6 - spare parts) should be replaced with new ones. Attach them loosely with M5 bolts (pos. 7); when fitting cutting dies the markings (M8, M10, M12) must be facing each other (figure 1 - detail).
5. The jaws are assembled in reverse order.
6. Insert the correct diameter of threaded rod, check the alignment of cutters and adjust as required. At the end tighten the M5 screws (pos. 7) with a hex key.

FIGURE 1

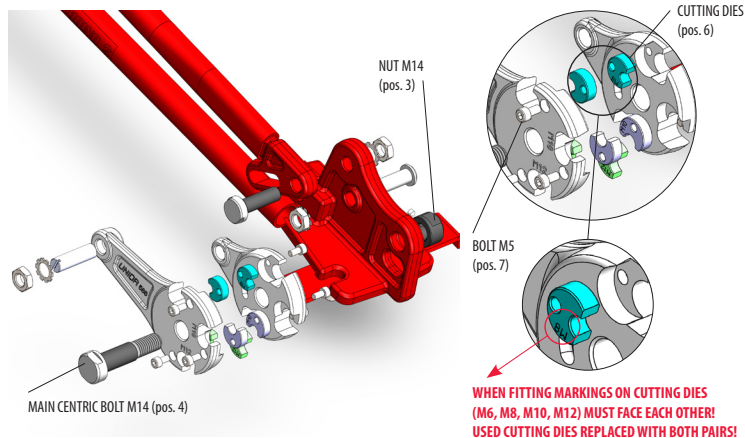

FIGURE 2

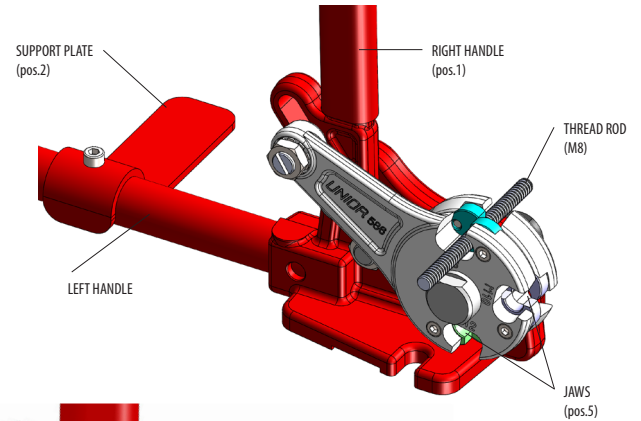

FIGURE 3

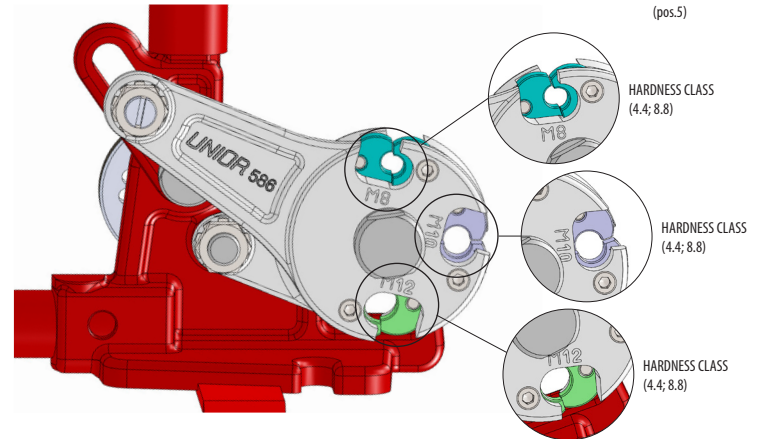

FIGURE 4

