

1689.1

EN Controlling caliper arm
for 1689

SLO Kaliber za 1689



Unior d.d.
Kovaška cesta 10
3214 Zreče, Slovenia
T: +386 3 757 81 00
www.uniorbiketools.com

90835444

 **UNIOR**[®]
BIKE TOOLS

uniorbiketools.com

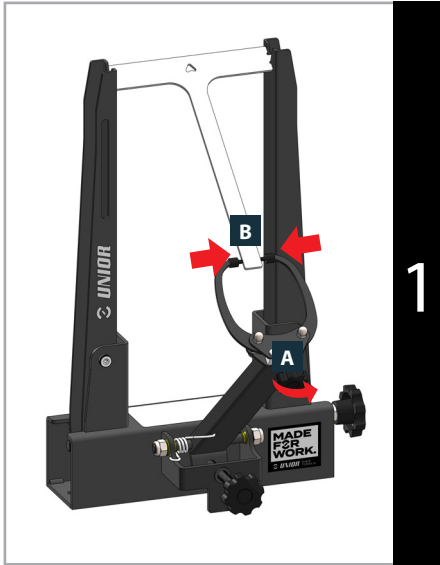

1689 professional wheel centering stand arm can get out of center after being used frequently. Controlling caliper arm enables us, to calibrate the stand arm back to its center position.

1

We insert the caliper into the centering stand and adjust the side knob (A) gently so the caliper is still able to rotate. We position it to approximately 45° angle and adjust the stand centering arm to the same position. Centering tips caliper knob (B) is adjusted, so either the tips caliper knob (B) is adjusted, so either the left or the right tip is touching the caliper.

2

By turning the left or the right nut (C), the centering stand arm position is being changed. We repeat adjusting of the centering tips until the arm is completely centered.

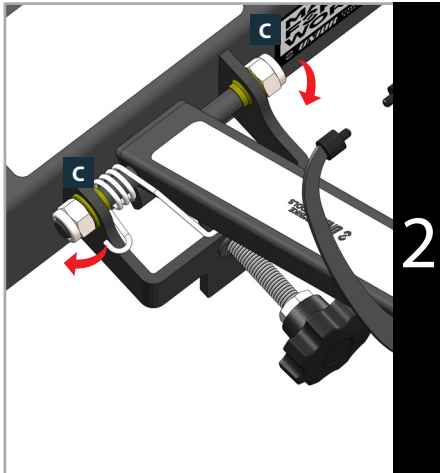

Roke 1689 profesionalnega stojala za centriranje po daljši uporabi občasno potrebujejo kalibracijo. 1689.1 kaliber nam omogoča, da navpični roki centrirnega stojala postavimo nazaj v središčni položaj.

1

Kaliber vstavimo v centrirno stojalo in nežno privijemo stranski nastavitveni vijak (A), tako da se kaliber lahko premika okoli svoje osi. Postavimo ga približno pod kot 45° in na enako pozicijo nastavimo roko centrirnega stojala.

Tipali centrirnega stojala nastavimo z nastavitvenim vijakom (B), tako da se bodisi levo ali desno tipalo prilega kalibru.

2

Z vrtenjem leve ali desne matice (C), se pozicija roke centrirnega stojala premika. Ponovimo postopek prilagajanja tipal kalibru, dokler ni roka v celoti v sredinski legi.